

NOTICE OF SPECIAL MEETING OF
BOARD OF DIRECTORS OF IRVINE RANCH WATER DISTRICT

To: Mary Aileen Matheis, Doug Reinhart, Peer Swan, and John Withers, Members of the Board of Directors of Irvine Ranch Water District.

Pursuant to the call of the President of Irvine Ranch Water District, notice is hereby given that a Special Meeting of the Board of Directors of Irvine Ranch Water District has been called and will be held on Thursday, August 8, 2019 at the hour of 2:00 p.m. in the Multi-Purpose Room of the Irvine Ranch Water District, Michelson Operations Center, 3512 Michelson Drive, Irvine, California, for the purpose set forth in the agenda.

This notice is given in accordance with the bylaws of Irvine Ranch Water District and Section 54956 of the California Government Code.

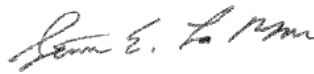

Steven LaMar
IRWD Board President

cc: Claire Hervey Collins – IRWD General Counsel

Note: This page is intentionally left blank.

AGENDA
IRVINE RANCH WATER DISTRICT BOARD OF DIRECTORS
SPECIAL MEETING

Strategic Planning Workshop
Thursday, August 8, 2019 at 2:00 p.m.

**IRWD Michelson Operations Center, 3512 Michelson Drive, Irvine
Michelson Operations Center Multi-Purpose Room**

Roll Call: Steve LaMar, Mary Aileen Matheis, Doug Reinhart, Peer Swan, and John Withers

Discussion Topics with Approximate Schedule:

2:00 – 2:05 p.m.	1. Communications to the Board: Written and Oral	LaMar
2:05 – 2:10 p.m.	2. Review of Agenda	Cook
2:10 – 2:20 p.m.	3. Review Updated 2019 IRWD Goals and Target Activities List	All
2:20 – 3:10 p.m.	4. Syphon Reservoir Improvement Project Public Outreach	All
3:10 – 4:00 p.m.	5. New Water Quality Regulations – PFOA and PFOS	All
4:00 – 4:10 p.m.	6. Break	All
4:10 – 4:30 p.m.	7. Closed Session CONFERENCE WITH LEGAL COUNSEL – ANTICIPATED LITIGATION Significant exposure to litigation pursuant to Government Code Section 54956.9(d)(2). (One (1) potential case.)	All, with Legal Counsel
4:30 – 5:00 p.m.	8. IRWD Emergency Power Capabilities	All
5:00 p.m.	9. Adjourn	

* * * * *

Availability of agenda materials: Agenda exhibits and other writings that are disclosable public records distributed to all or a majority of the members of the Irvine Ranch Water District Board of Directors in connection with a matter subject to discussion or consideration at an open meeting of the Board of Directors are available for public inspection in the District's office, 15600 Sand Canyon Avenue, Irvine, California ("District Office"). If such writings are distributed to members of the Board less than 72 hours prior to the meeting, they will be available from the District Secretary of the District Office at the same time as they are distributed to Board Members, except that if such writings are distributed one hour prior to, or during, the meeting, they will be available at the entrance to the Board of Directors Room of the District Office. The Irvine Ranch Water District Multi-Purpose Room is wheelchair accessible. If you require any special disability-related accommodations (e.g., access to an amplified sound system, etc.), please contact the District Secretary at (949) 453-5312 during business hours at least seventy-two (72) hours prior to the scheduled meeting. This agenda can be obtained in alternative format upon written request to the District Secretary at least seventy-two (72) hours prior to the scheduled meeting.

Note: This page is intentionally left blank.

A. Cant.

Review of the IRWD 2019 Goals and Target Activities

Summary:

On December 17 2018, the Board provided input on and adopted the IRWD 2019 Goals and Target Activities. The approved Target Activities are associated with 18 goals for IRWD to accomplish within the next five years. Staff has conducted a mid-year review of the Goals and Target Activities and has made minor revisions to update target completion dates and updated activities where appropriate. The following is an overview of the District's general strategic planning process and the mid-year revisions to the 2019 Goals and Target Activities. Staff recommends that the Board review and provide input on the mid-year revisions, as needed.

IRWD's General Strategic Planning Process:

In 2014, the District enhanced its approach to general strategic planning, incorporating the effective elements of IRWD's past strategic planning process along with added steps in the process and broader involvement among the IRWD Management Team. A graphical overview of IRWD's Strategic Planning Process is attached as Exhibit "A". The "baseline" documents used for strategic planning – the District Mission, Vision, and Values Statement and the IRWD Strategic Objectives – are attached as Exhibits "B" and "C", respectively.

One of the key steps IRWD's strategic planning process is to discuss how conditions that impact the District and the water industry are changing, and what goals the District should adopt and prioritize in consideration of these changing conditions. At mid-year, staff has not identified any new Changing Conditions for the Board's consideration that would require major revisions to IRWD's 2019 Goals and Target Activities, though new water quality regulations will undoubtedly require some new Target Activities in 2020. Staff is not proposing any major revisions to the 2019 Goals and Target Activities.

Mid-Year Revisions to Goals and Target Activities:

The IRWD Management Team has been using the 2019 Goals and Target Activities to prioritize and deploy District resources as well as to keep the Board apprised as to the progress made on each Target Activity. A mid-year review of the document has resulted in the need to update target completion dates, split off one activity into a goal and to update activities where appropriate. At the Strategic Planning Workshop, staff will present an overview of the revisions as attached in Exhibit "D".

Recommendation:

Staff recommends that the Board review and provide input on the mid-year revisions to the IRWD 2019 Goals and Target Activities.

Note: This page is intentionally left blank.

IRWD Strategic Planning Process

IRWD Mission, Vision, and Values



IRWD Strategic Objectives		
Customer Satisfaction	Water Reliability	Water Quality
Sewer Reliability	Cost Effectiveness	Innovation
Resource Recovery	Communication	Water Policy
Employee Satisfaction / Development	Environmental Commitment	



District Goals
5-year Planning Horizon



IRWD Target Activities

- Categories of Changing Conditions**
- Aging Infrastructure
 - Communication/Transparency
 - Energy
 - Expanded Services
 - Financial
 - Demographics
 - Regulatory / Legislative / Judicial
 - Political
 - Sustainability
 - Technology and Data Solutions
 - Water Supply
 - Workforce
 - Climate Change
 - Physical and Cyber Security
 - Regionalization



Exhibit "A"

Note: This page is intentionally left blank.

Exhibit "B"

Irvine Ranch Water District Mission, Vision, and Values

Mission

The mission of Irvine Ranch Water District, a public agency, is to provide high quality water and sewer service in an efficient, cost effective, and environmentally sensitive manner that provides a high level of customer satisfaction.

Vision

The Irvine Ranch Water District's vision is to achieve greater customer and employee satisfaction, increased reliability and resource conservation, and excellent external relationships with suppliers and others.

Values

Customer Service	We are dedicated to delivering superior service to our customers.
Employee Development	We are committed to recruiting and retaining top quality employees and to providing a workplace environment, training, and a recognition and reward system that enhances employee performance and satisfaction.
Resource Management	We are dedicated to providing, conserving, and maximizing the efficient use and reuse of water and renewable resources to the benefit of our customers and to enhance the environment.
Community Leadership	We will share our resources with the community through education, policy leadership and employee involvement.

Note: This page is intentionally left blank.

Exhibit C

Irvine Ranch Water District Strategic Objectives

Customer Satisfaction

Provide reliable, responsive, satisfying service to our customers in all aspects of our operations.

Water Reliability

Provide a continuous, reliable supply of water to our current and future customers that meets their needs and expectations, and accounts for changes in climate variability.

Water Quality

Deliver potable and non-potable water that meets all regulatory standards and customer requirements, and improve the water quality of local urban runoff.

Sewer Reliability

Plan, design, operate and maintain the sewer system in a consistent, reliable, and cost effective manner.

Cost Effectiveness

Optimize all of the District's activities to provide service at the lowest possible cost with high standards of quality and reliability.

Employee Satisfaction / Development

Provide employees with a working environment and the tools needed to optimize performance, productivity, and satisfaction and encourage individual career development and enjoyment.

Environmental Commitment

Conduct our business so that we either enhance our environment or minimize negative impacts.

Innovation

Optimize the use of technology and innovation in order to constantly improve processes to provide the most reliable and cost effective services to our customers.

Resource Recovery

Maximize the efficient recovery of resources including the recycling of water, recovery of energy, and use of organic materials for the benefit of our customers and the community.

Communication

Provide clear, accurate, transparent, and timely communication of information regarding our services, projects, finances, and activities utilizing multiple disciplinary tools that include educational programs, publications, electronic media and personal contact.

Water Policy

Develop and advocate for policies at the local, state, and federal levels that promote a reliable, high quality, and cost effective water supply for our customers, as well as the efficient use of resources.

Note: This page is intentionally left blank.

Exhibit "D"

Strategic Planning
2019 IRWD Goals and Target Activities List

Updated: August 8, 2019

GM = General Manager's Office
TS = Technical Services
OPS = Operations

POL = Water Policy
A&F = Administration and Finance
HR = Human Resources

Goals and Target Activities	Target Completion Date	Lead
<i>1. Optimize and protect local groundwater utilization</i>		
a. Conduct well treatment and conveyance study for Wells 51, 52, and two Tustin Legacy well sites	Nov. 2019	TS
b. Include IRWD's recycled water demands in OCWD's total water demand calculations	June 2020	POL
c. Collaborate with OCWD on South Basin Clean-up Project	Dec. 2020	POL
<i>2. Evaluate and invest in projects and programs that will enhance future long-term water supply reliability</i>		
a. Implement agreements with MWD and MWDOC that will provide water supply reliability from high priority water rights during periods of drought and supply interruptions	Dec. 2020	POL
b. Advocate methods for filling the Orange County Groundwater Basin, including development of concepts to promote exchanges	Dec. 2019	POL
e. Advocate for regional potable reuse projects including Metropolitan's Carson Regional Potable Reuse Project	Complete	GM
d. Work with OCWD on Green Acres Project water supply opportunities	June 2020	POL
e. Secure initial Title XVI funding for the Syphon Reservoir Improvement Project	Dec. 2019	GM
<i>3. Optimize use of Irvine Lake as a water resource facility for IRWD and its partners.</i>		
a. Resolve property issues between the County, the Irvine Company, Serrano Water District, and IRWD	Dec. 2019	A&F
b. Develop agreement with Serrano Water District and with the Baker Plant Partners for providing water system reliability utilizing Irvine Lake	Oct. 2019	POL
c. Complete final design of sloped outlet pipe to replace the Irvine Lake Outlet Tower	Dec. 2020	TS
d. Develop and implement updated agreement with the Irvine Company regarding yield from Irvine Lake and other issues.	Complete	A&F
e. Execute interim license with County of Orange and Serrano Water District regarding fishing in Irvine Lake	Complete	A&F GM

2019 IRWD Goals and Target Activities List

4. Develop water banking recharge, storage, and extraction capacity for IRWD and water banking partners, and store water as it becomes available		
a. Execute long-term unbalanced exchange agreements for Stockdale West	Sept. 2019	POL
b. Execute long-term exchange agreements to maximize benefits of non-SWP water	Aug. 2019	POL
c. Identify and procure additional supplies of water for banking purposes	Dec. 2019	POL
d. Integrate IRWD's Strand Ranch and Stockdale West properties into the Kern Fan Groundwater Sustainability Agency (GSA)	Complete	POL
5. Develop and implement the Kern Fan Groundwater Storage Project		
a. Finalize and execute Agreement and Bylaws with Rosedale to establish the Kern Fan Groundwater Storage Project JPA	Oct. 2019	POL
b. Identify and secure land as needed for the Kern Fan Groundwater Storage Project	June 2020	POL
c. Complete planning and environmental compliance work for the Kern Fan Groundwater Storage Project	May 2020	POL
d. Execute Agreements with State Agencies for the operation of the Kern Fan Groundwater Storage Project	Dec. 2020	POL
e. Secure water storage investment funding for the Kern Fan Groundwater Storage Project and advocate to include the project on the Bureau of Reclamation's Report to Congress	Oct. 2020	POL
6. Develop water recycling facilities and applications for optimal benefit		
a. Complete construction of Irvine Lake Pipeline North Conversion	Oct. 2019	TS
b. Complete Sewage Treatment Master Plan, including consideration of IBC flows	Mar. 2020	TS
c. Update the Salt Management Plan to assess impacts of seawater desalination on water recycling and other issues	Aug. 2019	POL
d. Perform CEQA, alternatives analysis and preliminary design for the Syphon Reservoir Improvement Project	July 2020	POL TS
e. Determine costs and benefits associated with procuring approximately 700 AF of recycled water storage in Santa Margarita Water District's Upper Oso Reservoir	Complete	TS
f. Complete IRWD Potable Reuse Feasibility Conceptual Study to explore Surface, Ground, Raw and Treated Water Augmentation options	Complete	TS
g. Work with other agencies on recycled water use opportunities	Mar. 2020	POL
h. Design and construct recycled water filtration facilities for San Joaquin Reservoir	Sept. 2020	TS
i. Develop customer guidelines for using recycled water	Jan. 2020	POL

2019 IRWD Goals and Target Activities List

7. Maximize resource recovery from fully functional biosolids and other resource recovery facilities		
a. Biosolids Class A Facilities operational and commissioned	Apr. 2020	TS
b. Secure agreements with multiple outlets for biosolids	Sept. 2019	OPS
c. Develop partnerships with others to utilize surplus capacity	Sept. 2020	OPS
d. Develop and implement plan to introduce FOG to the IRWD Biosolids Facilities	Dec. 2020	OPS
e. Develop plan to introduce foodwaste into the IRWD Biosolids Facilities	Dec. 2020	OPS
8. Improve energy service reliability, manage demands, and control costs		
a. Coordinate the construction and commissioning of energy storage installations with Advanced Microgrid Solutions	Complete	TS
b. Finalize contract to outsource operation and maintenance of biogas treatment and micro-turbine systems	Dec. 2019	OPS
c. Complete design and installation of compressed natural gas fueling station at the Operations Center	Dec. 2020	TS
d. Complete new water/sewer agency electricity tariff research in partnership with SCE that will reduce IRWD energy costs	June 2020	POL
e. Coordinate with SunPower to complete the installation of the photovoltaic (solar) energy system at the Baker Plant	Dec. 2019	TS
9. Maximize watershed protection		
a. Work with the County and others, permit and implement the Selenium TMDL offset trading program	Dec. 2019	OPS
b. Complete feasibility study of project to capture and treat urban runoff flows downstream from the San Joaquin Marsh utilizing funding from Measure M	Aug. 2019	OPS
c. Implement in-house Pre-treatment program elements: permitting, agreements, and monitoring reports	Dec. 2019	TS
d. Implement in-house FOG program, including billing	Dec. 2021	TS
e. Continue to work with OC Flood to ensure appropriate storm-flow capacity in San Diego Creek	Dec. 2019	GM
f. Complete construction of MWRP recycled water emergency diversion facilities to San Diego Creek	Oct. 2019	TS
g. Obtain riparian rights to divert water from San Diego Creek to ensure continued protection of water quality in Newport Bay	Complete	POL
h. Work with the County, OCWD, OCSD, and others to obtain a recycled water emergency diversion connection to the Santa Ana River	June 2020	TS
i. Obtain approval for the Total Nitrogen (TN) / Total Phosphorus (TP) Offset Plan from the Regional Board	Dec. 2019	TS
j. Participate in the Fecal Coliform Task Force to assist in the development of a reasonable TMDL	Dec. 2019	OPS

2019 IRWD Goals and Target Activities List

10. Ensure financial and rate stability		
a. Evaluate development and/or sale opportunities at IRWD properties	Dec. 2019	A&F
b. Complete development and leasing on remaining Sand Canyon campus	Jan. 2020	A&F
c. Update outstanding deed, access and other contractual restrictions related to real property	Sept. 2019	A&F
d. Update Cost of Service Study for the IRWD water and sewer systems that includes the Biosolids Project operating expenses	Mar. 2020	A&F
e. Develop approach for implementing a two-year budget and Prop 218 process	Complete	A&F
f. Develop an updated policy for funding the IRWD Infrastructure Replacement Program	Complete	A&F
g. Develop updated facility and pipeline unit costs into IRWD's Replacement Planning Model	Nov. 2019	TS
11. Identify, assess and implement new technologies, systems, and facilities to improve operating efficiency		
a. Complete addition of linear assets to the Enterprise Asset Management system; prepare scope for maintenance management mobility solution	Dec. 2019	OPS
b. Implement findings of IT-related existing/new technology opportunity assessment while maintaining IRWD's cyber security	June 2020	A&F
c. Assess the District's overall cybersecurity risk profile; establish overall plan for addressing cybersecurity awareness, education, response, and prevention at IRWD	Dec. 2019	A&F
d. Assess availability of data systems under certain service outage scenarios and implement program to strengthen systems	Dec. 2019	A&F
e. Convert IRWD email system from GroupWise to Outlook	Dec. 2019	A&F
f. Develop plan to assess IRWD's future warehousing needs	Dec. 2019	A&F
g. Evaluate office space needs to the Sand Canyon Headquarters Building and develop plan as needed	Dec. 2019	A&F
h. Develop plan for overall management of IRWD data (technical, financial, other)	June 2020	A&F
i. Update the Delegation of Authority policies	Dec. 2019	A&F
12. Enhance customer communications		
a. Enhance customer communication through an improved customer web access portal	Dec. 2020	A&F
b. Develop and implement Phase 3 of the Water Use Efficiency Outreach Program based on findings of the 2018 program	May 2020	POL
c. Implement redesigned customer bill to improve customers' understanding of IRWD rate structure; explain IRWD rate structure to customers through direct communications	Complete	A&F
d. Design and implement the Syphon Reservoir Improvement Project Outreach Program from EIR through Design Phase	July 2020	POL

2019 IRWD Goals and Target Activities List

<i>13. Maximize water use efficiency in the community</i>		
a. Complete a study to assess the potential for additional water use efficiency in IRWD’s service area	Sept. 2019	POL
b. Implement automated methodology for quantifying irrigated areas and meter locations by linking aerial image data to meter and parcel data	June 2020	POL
c. Expand / enhance water use efficiency demonstration gardens within the IRWD service area	Dec. 2019	POL
<i>14. Recruit, develop and retain a highly skilled, motivated, and educated work force</i>		
a. Assess the experience and training of IRWD employees to ensure a continued supply of highly-skilled labor, and develop programs, for example an Apprenticeship Program, to close any labor skills gaps identified	Dec. 2019	HR
b. Complete triennial Benchmark Salary Survey ensure District salaries remain competitive to market rates	Complete	HR
c. Negotiate new labor agreements with represented personnel	Complete	HR
d. Complete implementation of District-wide corporate values initiative	Dec. 2019	GM
<i>15. Guide and lead local, state and federal policies and legislation</i>		
a. Advocate for legislation or regulations that protects local investments in water recycling and extraordinary supplies, and protects IRWD’s ability to access those supplies, without penalty, during times of drought or shortage	Sept. 2020	GM POL
b. Advocate for an alternative funding source for safe and accessible drinking water in California, which is consistent with the Board’s adopted policy on a statewide public goods charge; oppose a statewide tax on water	Complete	GM
c. Engage in discussions surrounding water and sewer rates in order to protect the District’s ability to design and use a water budget-based tiered rate structure, including discussions related to Low Income Rate Assistance programs and Proposition 218 reforms consistent with Board direction	Sept. 2020	GM
d. Seek reauthorization of the Bureau of Reclamation’s Title XVI and the Water Storage Investment Programs	Dec. 2020	GM

2019 IRWD Goals and Target Activities List

<i>16. Engage and shape policies and regulations put forth by local, state and federal agencies</i>		
a. Engage productively with stakeholders, industry associations, and state agencies to effectively implement the enacted long-term water use efficiency legislation	Dec. 2020	GM POL
b. Obtain revisions to the State Water Resources Control Board's proposed amendments to the Recycled Water Policy	Complete	GM POL
c. Engage in discussions and provide input to the SWRCB on development of water loss standards	July 2020	GM POL
<i>17. Collaborate with other agencies and entities through leadership and innovation</i>		
a. Advocate for IRWD's Desalination Policy Principles	Aug. 2020	POL
b. Evaluate and promote opportunities for shared services such as third party billing for UC Irvine and Tustin	Dec. 2019	A&F
c. Support enhanced engagement and leadership roles within ACWA, WaterReuse, CASA, and other District associations	Dec. 2020	GM
d. Coordinate with interested entities to update South County Emergency Interconnect Agreement	Complete	POL
e. Work with other agencies to maximize Orange County benefits from IRWM processes, including capture of urban runoff by OCSD for use in GWRS	Complete	GM POL
f. As part of the IRWD Sewage Treatment Master Plan, work with OCSD to identify mutually beneficial opportunities for use of IRWD sewer flows	Mar. 2020	OPS
g. Complete the annexation process to bring sewer flows from Lake Forest into OCSD Revenue Area 14 (RA-14)	Complete	TS
h. Finalize agreement for a pilot program through which MWDOC can participate in IRWD's water banking program	Mar. 2020	POL
<i>18. Implement opportunities that enhance safety, security, and emergency preparedness throughout the District</i>		
a. Install security improvements at MWRP	Complete	A&F
b. Evaluate/implement security enhancements at District facilities	Mar. 2020	A&F
c. Design and construct improvements to eliminate the use of chlorine gas at Primary Disinfection Facility	Dec. 2020	TS
d. Update Emergency Operations Plan, including scenario training for the Emergency Ops Team & Policy Group	Sept. 2019	HR
e. Develop and implement Safety Training Management software	Complete	HR
f. Assess IRWD's ability to continue operation of key facilities during short- and long-term power outage scenarios	Aug. 2019	OPS
g. Conduct assessment for dedicated IRWD Emergency Operations Center (EOC)	Nov. 2019	HR
h. Revise all District energy control procedures (ECPs) and integrate with Maximo service work order system	Sept. 2020	OPS
i. Revise Specific Hazard Response Plans addenda to the Emergency Response Plan	Dec. 2020	HR TS

A. C.

Syphon Reservoir Improvement Project Public Outreach

Summary:

In January 2018, the IRWD Board of Directors approved a Professional Services Agreement with Fiona Hutton and Associates (FHA) to develop and implement a public outreach program for the proposed Syphon Reservoir Improvement Project. A customer survey and several focus groups were completed that gauged customers' perception, awareness, and views on recycled water and the project. At the Strategic Planning Workshop, staff with the assistance of FHA and consultants from Fairbank, Maslin, Maullin, Metz and Associates (FM3), will present the findings from the customer survey and focus groups along with an update on the implementation of the outreach program.

Background:

Consultants at FHA are currently implementing a public outreach program for the proposed Syphon Reservoir Improvement Project. The outreach plan for the project includes conducting a customer survey and several focus groups which were completed by FM3 and reviewed with the Water Resources Policy and Communications Committee on April 20, 2019. The purpose of the customer survey and focus groups was to assist staff with the development and implementation of the ongoing public communications and outreach program for the project. The goals of the outreach program are to:

- Share information about the proposed project with interested stakeholders;
- Present technical information to target audiences;
- Proactively contact community business leaders and interest groups; and
- Solicit and address comments and questions from stakeholders.

At the Strategic Planning Workshop the project team will update the Board on the following topics:

- Survey and focus groups results;
- Outreach activities to date; and
- Community outreach training and preparation.

Staff and the consultant team will also present details associated with the analysis of the survey and focus group results.

Fiscal Impacts:

None.

Committee Status:

This item was reviewed by the Water Resources and Policy Committee on April 20, 2019, and July 11, 2019.

Recommendation:

RECEIVE AND FILE.



New Water Quality Regulations: PFOA & PFOS

Summary:

The presence of poly- and per-fluorinated alkyl substances (PFAS) in the environment has become an important issue throughout California and the United States. Both the U.S. Environmental Protection Agency and the California Division of Drinking Water (DDW) have announced important planned regulatory actions including the process for developing maximum contaminant levels (MCLs) and other important regulatory thresholds. Staff will provide important information regarding PFAS, covering:

- Technical background explaining what PFAS are and where they are found;
- Details about the statewide investigation by DDW;
- Impacts from PFAS to the Orange County Groundwater Producers;
- Treatment Solutions;
- Public Outreach;
- Legislative and Regulatory Actions; and
- Regional Solutions and Next Steps.

Background:

In March 2019 DDW initiated a statewide investigation of PFAS in drinking water including the identification of sources. Orange County Water District, on behalf of the Orange County Groundwater Producers, began testing of drinking water wells throughout the basin that DDW had identified as known or suspected to contain PFAS. Nine of the Producers, including IRWD, have wells with detectable levels of PFAS.

OCWD has undertaken numerous activities to respond the investigation including pilot testing of proven PFAS treatment technologies in the Orange County groundwater basin as well as initiating a planning study to evaluate the installation of PFAS treatment systems throughout the basin and among co-located producer wells. OCWD has also engaged local and statewide legislators and regulators to respond to proposed changes in the current Notification and Response Levels. Staff will discuss the potential impacts of these proposed changes as well as options for action by IRWD.

Committee Status:

This item was discussed at the Engineering and Operations Committee on April 16, 2019.

Recommendation:

RECEIVE AND FILE.

List of Exhibits:

Exhibit "A" – Draft Presentation on New Water Quality Regulations: PFOA and PFOS

Note: This page is intentionally left blank.



Irvine Ranch
WATER DISTRICT

NEW WATER QUALITY REGULATIONS: PFOA & PFOS

IRVINE RANCH WATER DISTRICT



INTRODUCTION AND TECHNICAL BACKGROUND

- What are PFAS?
- Where are they found in commerce and in the environment?
- Important regulatory thresholds:
 - EPA Health Hazard Advisory 70 ppt
 - California Notification Levels: PFOA 14 ppt; PFOS 13 ppt (June 2018)
 - California Response Level: PFOA + PFOS 70 ppt
 - DDW has signaled its intent to lower Notification and Response Levels

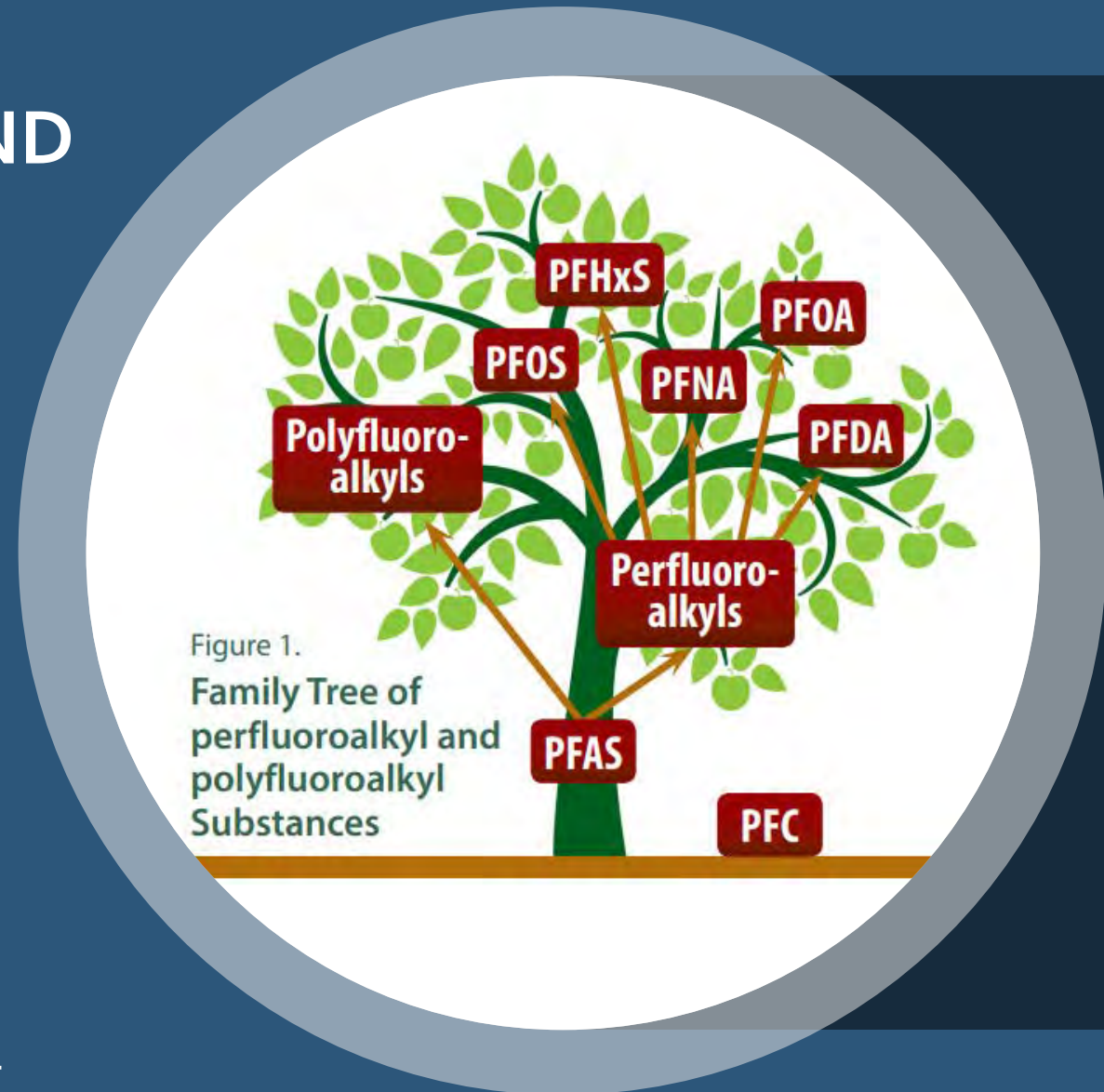

STATEWIDE INVESTIGATION

April 2019 Division of Drinking Water initiated a three-phase PFAS investigation:

Phase I included drinking water wells with known or possible PFAS contamination (OPA₁ & DRWF#₂)

Phase II includes source investigation, refineries, bulk terminals, fire training facilities

Phase III includes secondary manufacturing sites, wastewater treatment & pretreatment plants

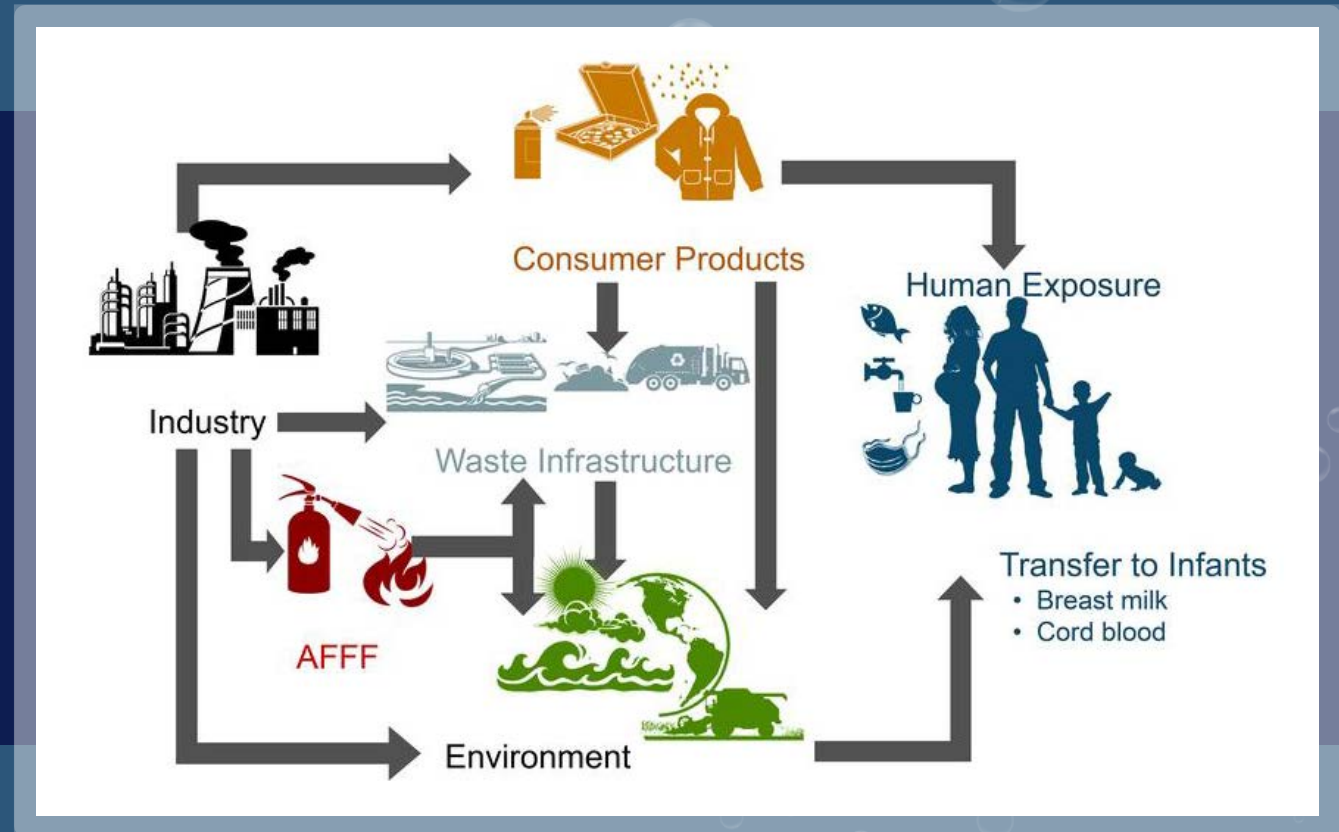

ORANGE COUNTY GROUNDWATER PRODUCERS IMPACTS

- Nine Groundwater Producer Agencies with PFAS: Anaheim, East Orange, Fullerton, Garden Grove, IRWD, Orange, Santa Ana, Serrano WD, and Yorba Linda WD
- Averages of 51 tested wells: PFOA 20ppt, PFOS 17 ppt. two wells exceed Response Level of 70 ppt.
- If DDW proposed Response Levels are adopted, 71 of 200 wells would exceed (loss of 100,000 acre-feet, \$50 million in imported water annually)
- Wellhead treatment costs estimated at \$200 million

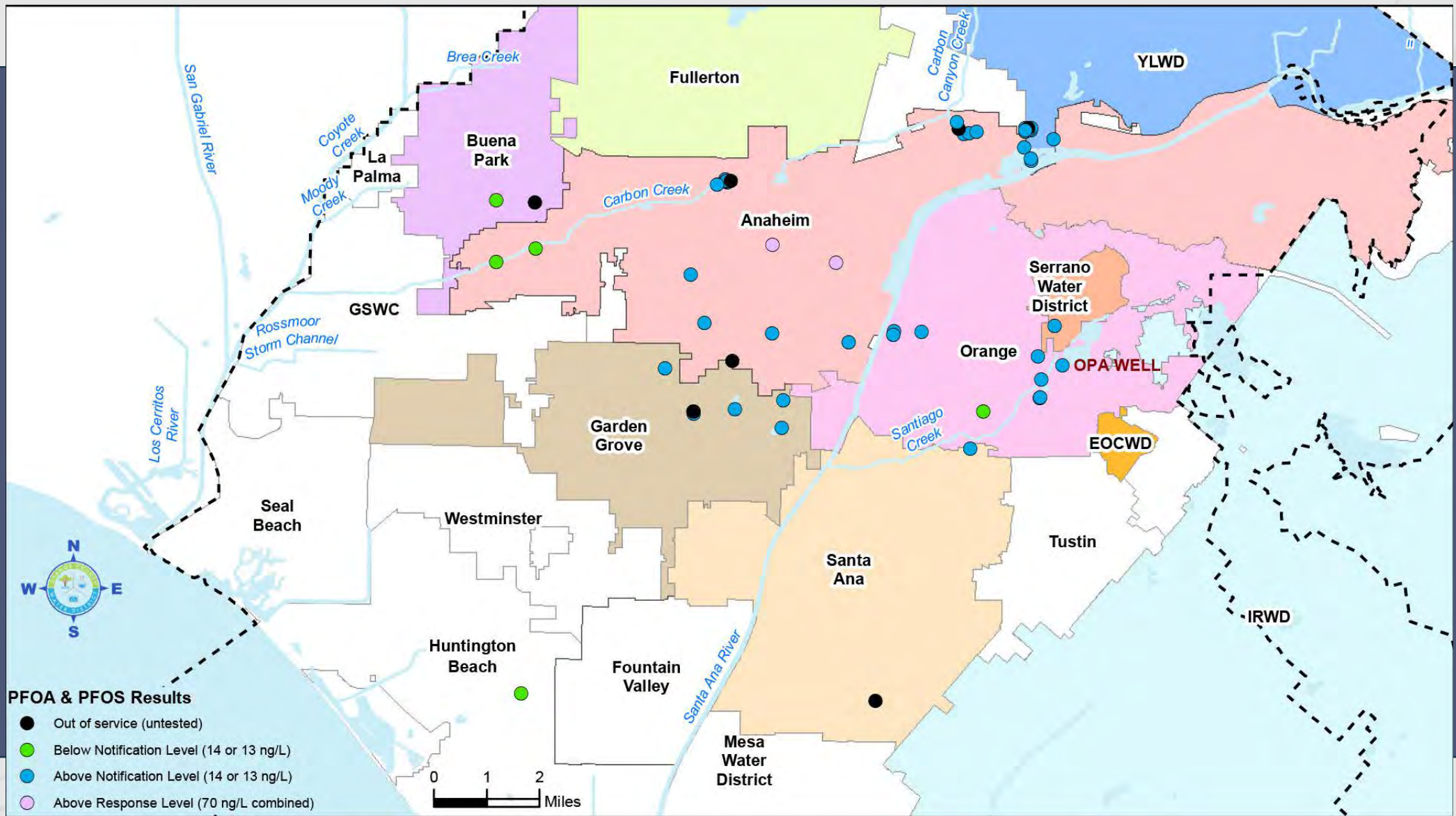

SANTA ANA RIVER AT IMPERIAL: PFOA, PFOS RESULTS

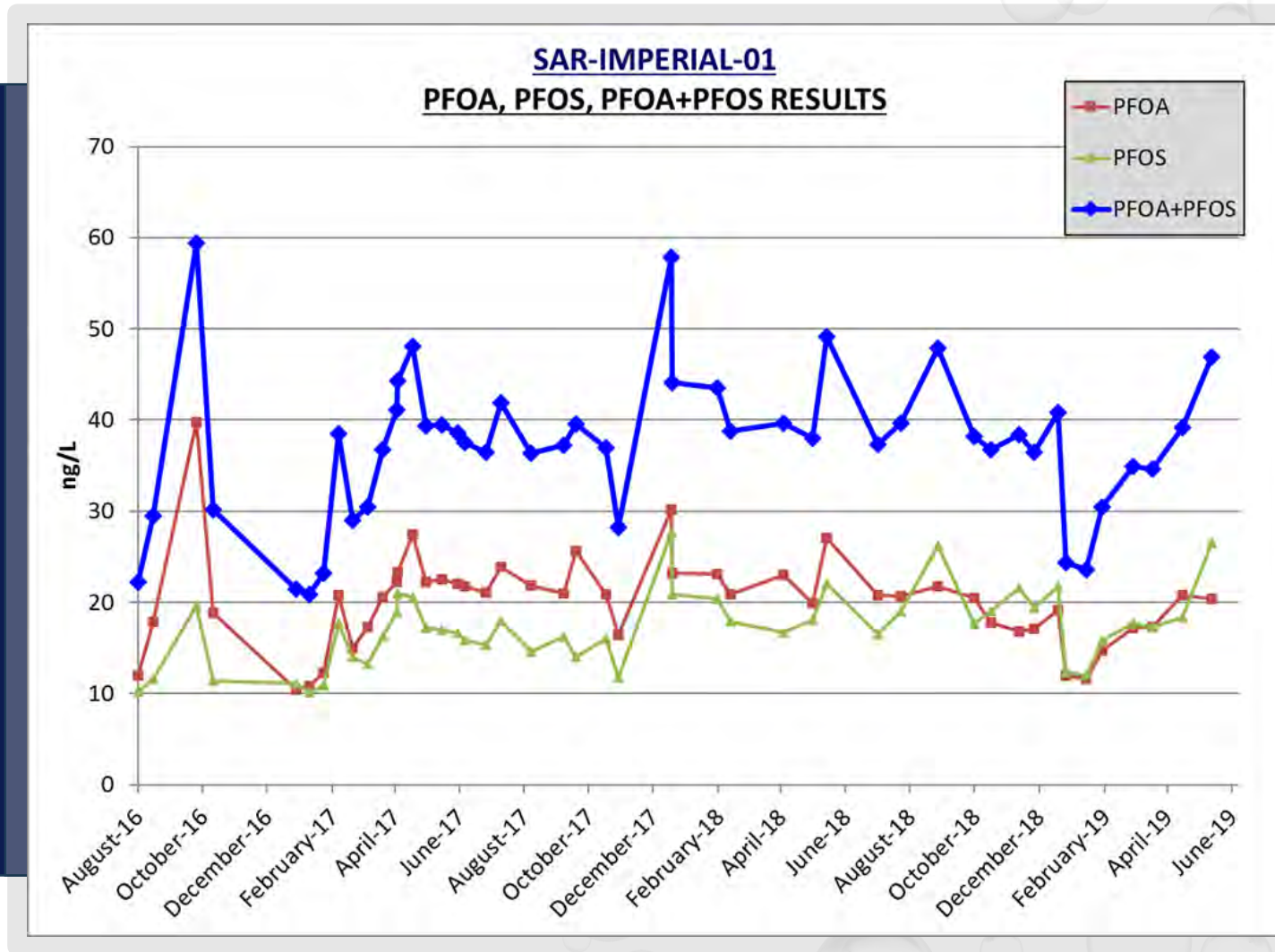

- Monitoring and routine meetings
- Created outreach content
- Initiated Pilot testing for various treatment technologies
- Issuing Planning Study (RFP) that will assess feasibility of treatment for individual producers, including integration of well operations and among producers.
- Direct outreach to DDW and CalEPA Secretary Jared Blumenthal, CA legislature, and local govt. officials



TREATMENT SOLUTIONS

- Evaluating treatment options for potable and recycled water systems
- Proven technologies: granulated activated carbon, ion-exchange resin, nanofiltration, and reverse osmosis
- Unknowns: future regulatory thresholds and the inclusion of shorter chain PFAS chemicals which can be more challenging to treat



IRWD PUBLIC OUTREACH

- PFAS information posted on IRWD website in June 2019
- Continued coordination with OCWD on public outreach materials
- Participation on ACWA Water Quality Committee communication message development
- Most important message: *IRWD drinking water does not contain PFAS*



LEGISLATIVE AND REGULATORY ACTIONS

- Approx. 30 federal bills in 2019
- Recent & expected USEPA actions
- Two state bills in 2019
 - AB 756 (Garcia) was passed and signed into State law July 31, 2019
 - AB 841 (Ting) became a two-year bill
- Pending state regulatory actions:
 - Source control
 - Implementation of AB 756
 - Changes in the Notification & Response Levels
 - Establishing a PHG & MCL



Regional Solutions, Next Steps

- Study treatment options
- Participate in OCWD Planning Study with OC Groundwater Producers
- Work cooperatively with associations including ACWA, CASA, SCAP and WateReuse
- Legislative and regulatory engagement, as appropriate
- Monitoring of potable and recycled water
- Work with Navy to address El Toro Base issues



Irvine Ranch
WATER DISTRICT

QUESTIONS?

Visit irwd.com for more information

1.6.1

IRWD Emergency Power Capabilities

Summary:

Staff has reviewed the District's emergency generation capabilities and available diesel fuel supplies throughout the District. Staff will present details from the review along with a recommendation to develop and implement a plan to sustain emergency operations for up to three days under certain emergency scenarios.

Background:

IRWD's existing emergency generation systems are designed to provide back-up power during short-term (i.e., 24 hour maximum) power outages. During extended outages (up to three days), the ability to provide services becomes more dependent on resources beyond the District's capabilities. In order to continue services critical for human health and safety (specifically, potable water treatment / deliveries and sewage collection / treatment) during an extended power outage, IRWD will need to rely substantially on the following:

- Orange County Sanitation District's (OCSD) system to accept diverted sewage flows;
- Imported potable water supply from Metropolitan Water District;
- Diesel fuel supplies in storage;
- Natural gas from Southern California Gas Company; and
- Conservation efforts by IRWD customers.

To sustain the generation of electricity by IRWD emergency generators, a sufficient supply of fuel must be available to maintain uninterrupted service during extended power outages. Currently, the District has adequate diesel fuel storage capabilities to support operations for approximately 24 hours; after which time fuel supplies must be replenished. An extended outage caused by an earthquake may also damage major transportation routes. Increasing diesel fuel storage throughout the District would allow for continued operation of key facilities during long-term power outages.

To ensure uninterrupted operation of IRWD facilities during long-term power outages, staff recommends the following:

- Develop a plan to sustain IRWD operations for three days;
- Perform an engineering evaluation; and
- Include project(s) in the fiscal year 2019/20 Capital Budget.

Staff will present the details of the review at the Strategic Planning Workshop. A copy of the presentation is attached as Exhibit "A".

Committee Status:

This item was reviewed by the Engineering and Operations Committee on June 26, 2019.

Recommendation:

THAT THE BOARD ADOPT A TARGET OF THREE DAYS TO MAINTAIN SERVICE TO IRWD CUSTOMERS, BASED ON THE SCENARIO ASSUMPTIONS IN THIS PRESENTATION, AFTER WHICH STAFF WILL DEVELOP A PLAN TO SUSTAIN IRWD OPERATIONS FOR THE TARGETED EXTENDED OUTAGE PERIOD UNDER THE ASSUMED CONDITIONS.

List of Exhibits:

Exhibit "A" – Draft IRWD Emergency Power Capabilities Presentation

IRWD Emergency Power Capabilities

IRWD Strategic Planning Workshop

August 8, 2019



Flow Diagram of Daily Operations

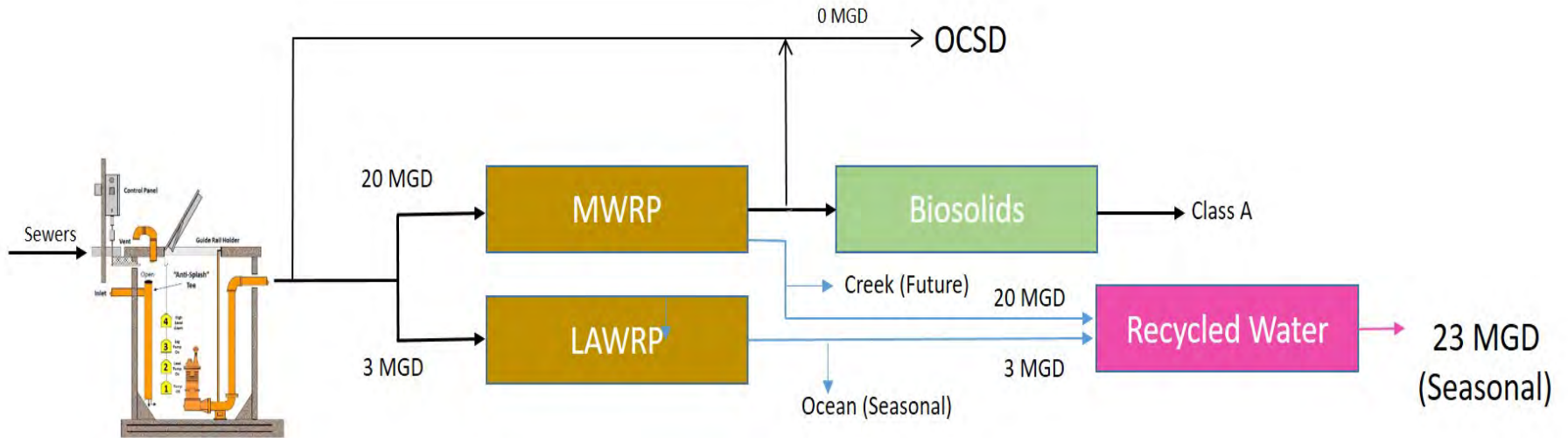

Lift Stations

Ground Water 75%

Domestic Water Treatment
And Conveyance

Imported Water 25%

40-75 CFS
(Seasonal)



Customers

Interruption of Electrical Power from SCE

Assumptions for Extended Outage Scenario:

- Orange County Sanitation District is available to accept diverted sewage flows;
- Imported water remains available ;
- Diesel fuel supply is available to begin delivery on day two of the power interruption ;
- Natural gas from Southern California Gas is available ;
- Conservation efforts within the District ;
- Portable generator inventory deployed; and
- Average generator load is at approx. 50%.



Current Back-Up Power Capabilities

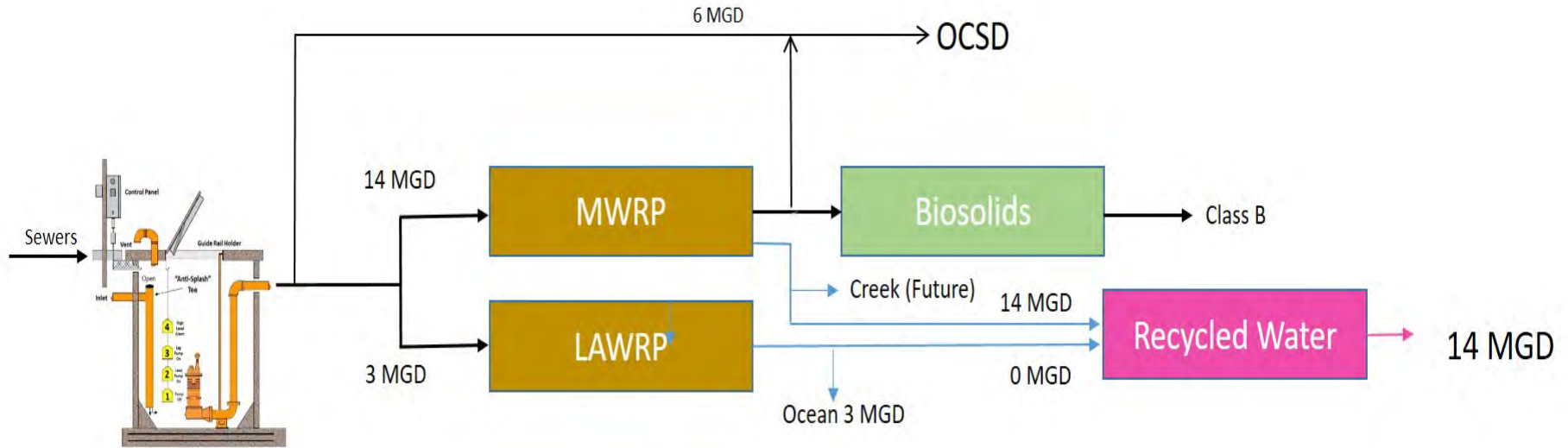

Lift Stations

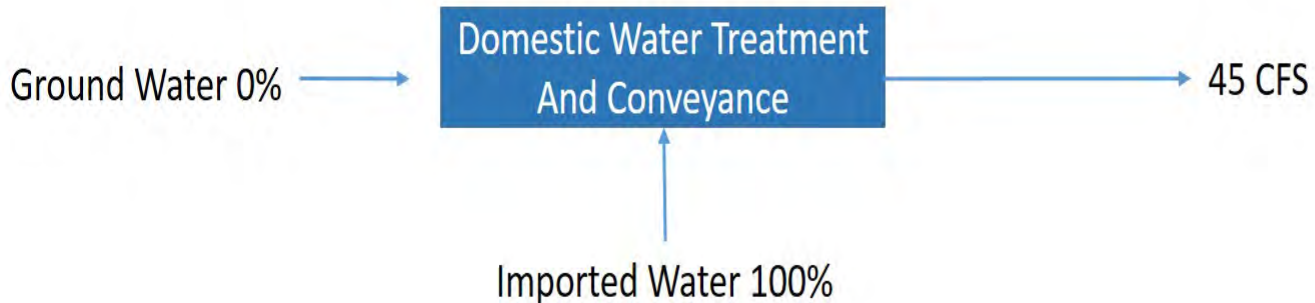

Customers

Recommended Actions

- Adopt a target of three days to maintain service to IRWD customers, based on the scenario assumptions in this presentation;
- Develop a plan to sustain IRWD operations for the targeted extended outage period and assumed conditions;
- Perform an engineering evaluation to implement this objective; and
- Create a project for inclusion in the capital budget.



Questions?

